

V5052

16-Port PCI Express FPGA Card

Benefits

High density FPGA PCIe Card for next generation data distribution, processing, and networking systems

Supports 1/10/25/40/100 Ethernet, 1/2/4/8/16/32G Fibre Channel, sFPDP1/2/2.5/10G, ARINC 818-2

Out-of-the-box ultra low latency and high bandwidth performance

Programmable FPGA with a powerful development framework

Next generation host interface connection bandwidths

Wide range of FPGA sizes and memory configuration options

Features

Four QSFP28 ports accommodate:

- 4x 100G Ethernet
- 4x 40G Ethernet
- 16x 25G Ethernet
- 16x 10G Ethernet
- 16x 1G Ethernet
- 16x 1/2/4/8/16/32G Fibre Channel
- 16x 1/2/2.5/10G sFPDP
- 16x ARINC 818-2

Xilinx Virtex UltraScale+ FPGA (VU5P – VU11P)

Supports PCIe Gen3 x 16 and Gen4 x 8

PPS time synchronization with nSec resolution

Thermal sensors for monitoring card temperature

Robust FPGA development framework

Advanced APIs that support multi-core and multi-processor architectures

Optimized Linux drivers and libraries

Overview

The V5052 is the next generation of New Wave DV's flagship programmable network products and the industry's highest performance FPGA network card in production today. It is powered by the latest Xilinx Virtex UltraScale+ FPGA technology. Purpose-built for processing network data in real time, the V5052 has been optimized to provide the lowest possible latency and the highest possible performance. This makes it ideal for executing sophisticated algorithms, processing streaming data, and running a wide range of functions as close as possible to the network.

To meet priority deadlines for rolling out new products, the expressXG™ Development Framework provides the standard toolset and debug capabilities required to create applications on the V5052 network card quickly.



V5052

16-Port PCI Express FPGA Card

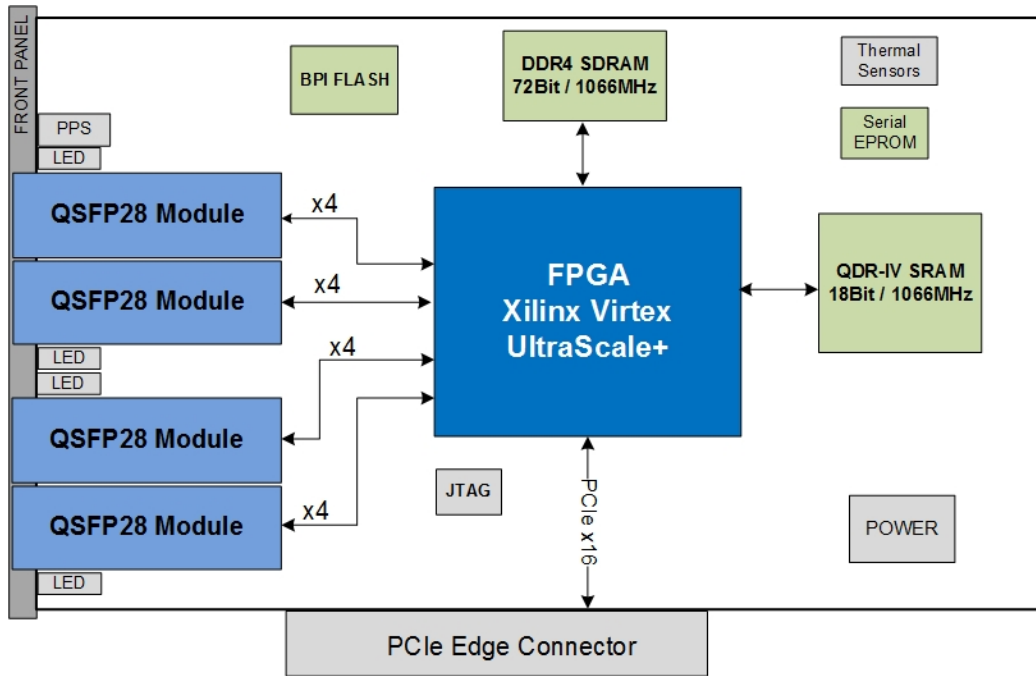

> V5052 Block Diagram

Simplified Programmability Framework

The V5052 ships with the expressXG Development Framework, a fully integrated and flexible toolset that provides the infrastructure necessary to ensure rapid deployment of applications. The framework abstracts the details of Ethernet/Fibre Channel protocols and interfaces, memory controllers and host fabric interfaces, thereby reducing the development effort and schedule for designers to implement custom solutions. High performance software libraries and drivers ensure that the card is running “out of the box.”

Multi-processor Multi-core Support

The V5052 is uniquely suited to system architectures involving multiple processing cards on a common switched data plane. Specifically, the V5052 supports shared access from multiple host processors, enabling it to function as a cost effective, high-performance gateway. This feature enables a single high-speed pipe to carry multiple virtual channels in systems that need to spread or load balance sensor data across processor farms.

Optional Offload Engines

The V5052 optionally has built-in support for Ethernet and Fibre Channel upper layer protocols. When used as a gateway, the V5052 supports PCI Express over the edge connector for processor communication and comes with high level APIs for control and data transfer resulting in a simplified programming model.

Operation Customization

The V5052 is an FPGA based network card that can be customized to fit your requirements. New Wave provides access to the FPGA for customers to customize, however New Wave can also modify existing cores or develop new cores for your applications. If you have specific networking requirements, New Wave DV can help you accomplish your goals.

V5052

16-Port PCI Express FPGA Card

Complete Product Support Program

Our customers can attest to our exceptional support. New Wave DV provides an industry-standard warranty on its products, but it is the human factor that makes our support so valuable to our customers. Our team takes the time and effort to ensure a positive customer experience.

Our Commitment

New Wave DV is committed to providing the latest innovations in technology, architectures, and techniques to keep our customers one step ahead of the rest. Our products, complete with expressXG Development Framework, are designed to offer our customers an entirely unique out-of-the-box experience.

Ordering Information

400-05052-00-00: V5052 PCIe Network Card, Virtex UltraScale+ VU5P

Other product configurations are available. Please contact us.

Technical Specifications

NETWORK INTERFACE

Four QSFP28 optical ports

ETHERNET PROTOCOLS

TCP, UDP, ARP, ICMP, Multicast, Broadcast

FIBRE CHANNEL PROTOCOLS

RDMA, AV, ASM

ADDITIONAL PROTOCOLS

sFPDP, ARINC 818-2

FPGA DEVICE

Xilinx Virtex UltraScale+ (VU5P to VU11P)

Xilinx Virtex UltraScale (VU080-VU190)

Xilinx Kintex UltraScale (KU095-KU115)

MEMORY

One bank of 4GB to 18GB 72-bit up to 1066MHz DDR4 SDRAM

One bank of 36Mbit to 144Mbit 18-bit 1066MHz QDR-IV SRAM

FLASH

One 32MB memory for storing a default configuration image

HOST INTERFACE

PCI Express Gen4 x8 PCI

Express Gen3 x16

EXTERNAL INTERFACE

32 differential pairs (user configurable)

PPS Interface for time synchronization with μ second resolution

RS-232 serial interface for debug

THERMAL SENSORS

2 digital temperature sensors

COMPLIANCE

PCI Express Card Electromechanical Specification, Rev 2.0

IEEE 802.3ae 2002

IEEE 802.3ba 2010

FC-FS-3 INCITS 470-2011

FCC 47 CFR Part 15, Subpart B, Class A (USA)

IEC 60950-1 (International)

RoHS Directive 2002/95EC

DIMENSIONS

111.15 mm x 167.65 mm (standard height, half-length)

POWER REQUIREMENTS

Maximum 65W (preliminary)

TEMPERATURE

Operating: 0 to 45°C

Storage: -40°C to 85°C

FOR MORE INFORMATION

www.newwavedv.com
info@newwavedv.com
Phone +1 952-224-9201

New Wave DV
4950 W 78th St. Minneapolis,
MN 55416 USA

