

# 1394b AS5643 Offload Engine IP Core

## Applications

- Avionics vehicle and mission systems
- Industrial/Machine vision systems

## Benefits

- Increased performance with hardware-based AS5643 offload
- Additional diagnostics and programmable operation features
- Leverage proven technology for standard interface implementation

## Features

- AS5643-compliant interface with hardware-based STOF offload
- Hardware DMA engines with message label mapped buffers
- STOF transmitter and receiver hardware functions
- Supports S100/S200/S400/S800/S1600/S3200 data rates
- Configurable number of nodes and ports in a single FPGA
- AXI-based host interface for embedded or PCIe-based processors

## Overview

The New Wave Design and Verification (New Wave DV) 1394b AS5643 Offload Engine core provides a complete hardware IP solution for the 1394b AS5643 protocol.

The core provides hardware-based AS5643 message label filtering, hardware mapping of AS5643 message label to host memory, and complete offload of 1394 AS5643 message handling including: Asynchronous Transmit, Isochronous Receive, STOF receive/transmit handling, STOF regulated transmit functions, Self ID operations, vertical parity, and CRC generation/checking.

The host interface to the core can be AXI or PCIe. The core is built for dropping into an FPGA and providing the complete design from processor interface to 1394b AS5643 network interface.

This core is targeted towards applications in aerospace and has been used on a wide range of parts at varying operating rates. The core comes with test-benches and example code, making design integration a straightforward task.

Evaluation versions of the 1394 AS5643 Offload Engine IP core are available and New Wave DV has a set of standard form-factor boards featuring FPGAs, 1394b connectors and transformers, and off-the-shelf reference designs for quick evaluation of the IP core.

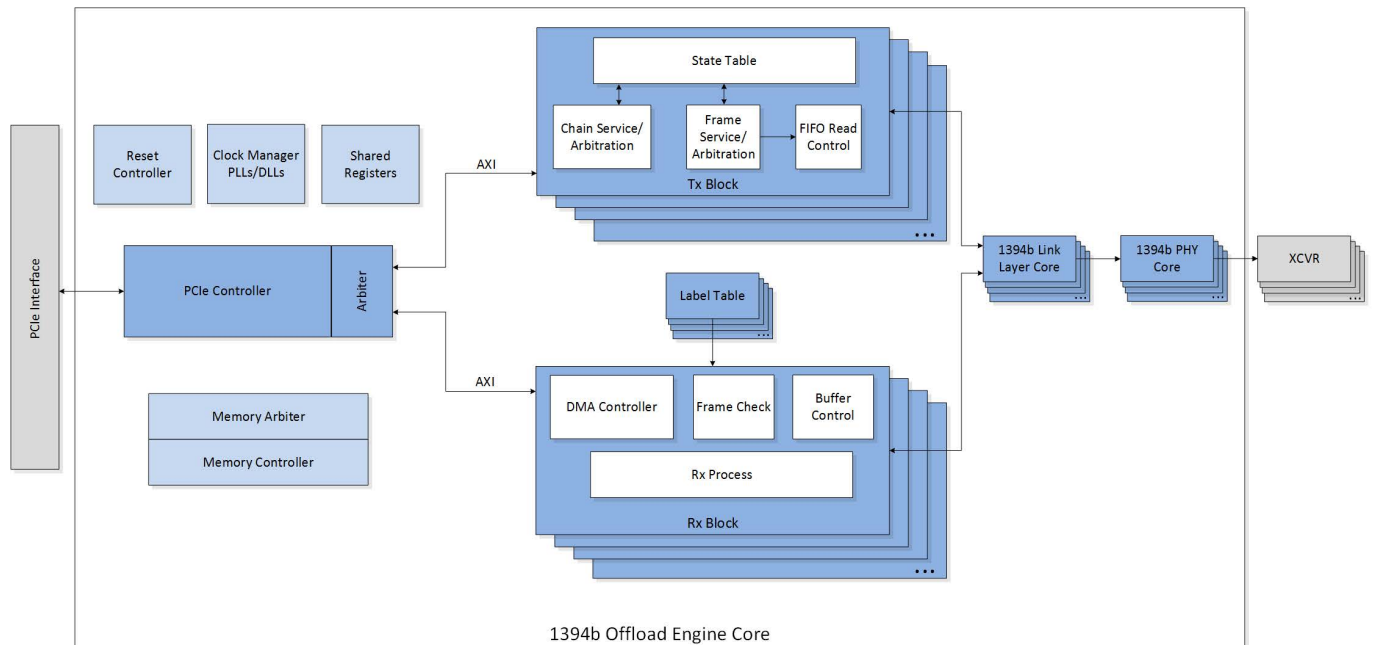

# 1394b Offload Engine IP Core

## IP Core for 1394b AS5643

### Functional Description

The 1394b AS5643 Offload Engine IP core was developed as a 1394b-AS5643 compliant IP-based replacement to existing discrete 1394b integrated circuits without AS5643 support. The IP core implementation provides significant operational benefits as well as size, weight, and power savings over legacy discrete component implementations.

Use of an IP-core based implementation for 1394b also significantly mitigates future obsolescence issues. Discrete component 1394b options are now offered by only one vendor. Since the AS5643 Offload Engine core from New Wave DV can operate in all FPGA technologies including but not limited to Xilinx, Intel (Altera), and Microsemi; future implementation options are assured.

In the AS5643 Offload Engine core, New Wave DV provides capabilities that are not available in the 1394b discrete components. These additional capabilities include AS5643 label table filtering, message label to host buffer DMA mapping, diagnostic information, hardware-based AS5643 STOF offload, AXI-based host interfaces, and custom configuration options.

The Offload Engine core can be instantiated multiple times in a single part. The core also supports a configurable number of ports per instantiation. Customers have taken advantage of this capability to build devices with AS5643 node port counts of 1, 2, 3, 4, or higher. This customization allows for the most efficient use of FPGA/ASIC resources.

By taking advantage of modern FPGA technology, and using this IP core along with 1394b PHY core from New Wave DV, it is feasible to implement in one FPGA what used to be implemented in 8-10 discrete components. Each of those discrete integrated circuits being the size of the one FPGA/ASIC using the New Wave DV IP cores. This is a board-space savings for high-density 1394b applications of roughly 10:1.

### New Wave DV 1394b Offload Engine Cards

In addition to the 1394b Offload Engine core, New Wave DV provides standard form-factor 1394b Offload Engine interface cards that incorporate the 1394b Offload Engine interface core along with high performance DMA engines and software drivers. Available in PMC/XMC form-factors, New Wave DV 1394b Offload Engine cards provide up to 4 ports in a single card. Reach us at [info@newwavedv.com](mailto:info@newwavedv.com) to ask about our 1394b Offload Engine solutions.

### Technical Specifications

**Core is delivered in netlist format including constraint files.**

#### SUPPORTED DEVICES

Xilinx: Virtex, Kintex, Artix, Zynq FPGAs  
Intel (Altera): Stratix, Arria, Cyclone FPGAs  
Microsemi: SmartFusion2, Igloo2 FPGAs

#### SUPPORTED RATES

S100/S200/S400/S800/S1600/S3200

#### OPERATING FREQUENCIES

S100: 12.288Mhz  
S200: 24.576MHz  
S400: 49.152MHz  
S800: 98.304Mhz  
S1600: 196.608Mhz  
S3200: 196.608Mhz (double data width)

### Our Commitment

New Wave DV is committed to providing the latest innovations in technology, architectures, and techniques to keep our customers one step ahead of the rest. Our products, complete with the Development Framework, are intended to offer our customers an entirely unique out-of-the-box experience.

### Complete Product Support Program

Our customers can attest to our exceptional support. New Wave DV provides an industry-standard warranty on its products, but it is the human factor that makes our support so valuable to our customers. Our team takes the time and effort to ensure a positive customer experience.

### Ordering Information

700-FW400-00-00: 1394b AS5643 Offload Engine core, S100/S200/S400 rate support

700-FW400-01-00: 1394b AS5643 Offload Engine core, S800/S1600/3200 rate support

Other product configurations are available. Please contact us.

#### FOR MORE INFORMATION:

[www.newwavedv.com](http://www.newwavedv.com)  
[info@newwavedv.com](mailto:info@newwavedv.com)  
Phone +1 952-224-9201

New Wave DV  
4950 W 78th St. Minneapolis,  
MN 55435 USA

