

# V5031

## Quad-Port PCI Express FPGA Card

### Applications

- Ultra-low latency electronic trading
- Sensor and radar systems
- Network security
- Network monitoring and optimization

### Benefits

- Launch new revenue generating financial trading products
- Deliver real-time service reliability to your customers
- Deploy applications on the industry's highest performance and lowest latency programmable network card

### Features

- Quad 1/10 Gigabit Ethernet SFP/SFP+ optical ports
- Altera Stratix V FPGA (scalable from A3 to AB)
- Two independent banks of up to 8GB DDR3 SDRAM each
- Four independent banks of up to 144Mbit QDRII+ SRAM each
- 8-lane PCI Express Gen 3 host interface
- On-board FLASH for dual boot support
- Mini SAS transceiver interface for intercard communication
- RS-232 interface for application debugging
- PPS interface for time synchronization with  $\mu$ Sec resolution
- Built-in support for RTP (IEEE 1588)

### Overview

The V5031 is the fifth generation of New Wave DV's flagship products and the industry's highest performance 10GE FPGA network card in production today. It is powered by the latest Stratix V FPGA technology from Altera. Purpose-built for processing network data in real time, the V5031 has been optimized to provide the lowest possible latency and the highest possible performance. This makes it ideal for executing sophisticated financial trading strategies, processing market data feeds, and running a wide range of algorithms as close as possible to the network.

To meet priority deadlines for rolling out new financial products, the expressXG™ Development Framework provides the standard toolset and debug capabilities required to create applications on the V5031 network card quickly.

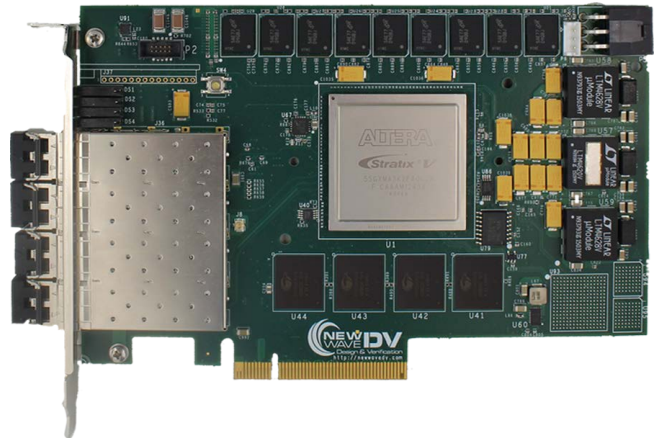

# V5031

## Quad-Port PCI Express FPGA Card

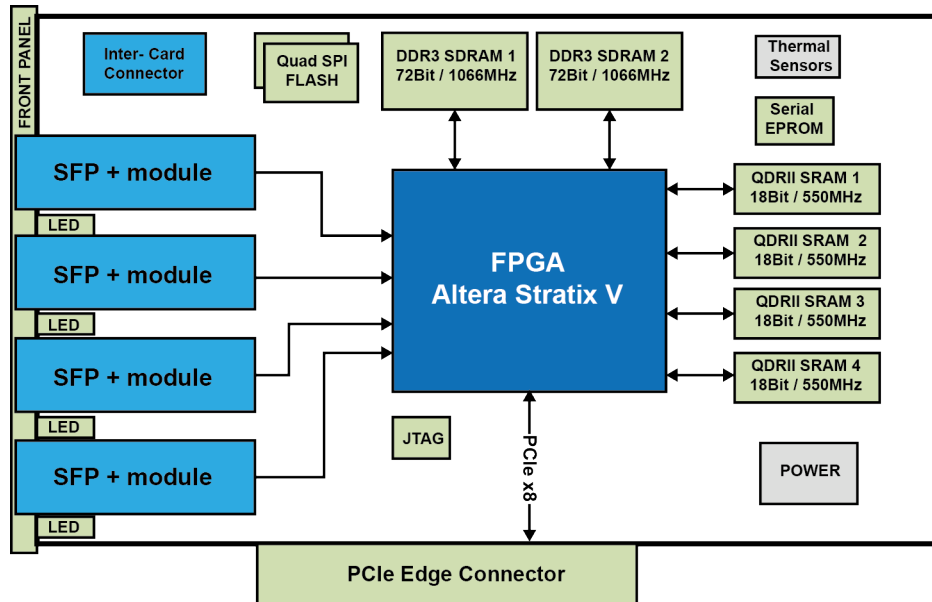

> V5031 Quad -Port PCI Express FPGA Card Block Diagram

## Functional Description

The V5031 is a quad port 10 Gigabit Ethernet FPGA network card with PCI Express Gen 3 host interface. The network interface is provided through SFP+ pluggable transceivers that support short and long range fiber.

By combining key technology from Altera, the V5031 network card features the Stratix V family of FPGAs, offering a range of logic elements from 340,000 to 952,000. The Stratix V scalability and high density makes it possible to support a wide range of applications and to implement complex algorithms. Its high capacity integrated transceivers are optimized for high-performance, high-bandwidth applications. The SFP+ pluggable transceivers communicate directly with the Stratix V device using built-in physical layer interfaces (PHY), which dramatically reduces the latency for data coming from and going to the network interface.

The V5031 is available with a generous amount of memory to handle the most demanding applications. The card features two banks of up to 8GB 72-bit wide memory running at a maximum clock rate of 1066MHz. They offer a potential 17 GBytes/s raw bandwidth each. This could be used to provide buffering to sustain burst traffic over 10 Gigabit Ethernet networks with data accessible from applications running on the FPGA or from the host.

In addition, there are four banks of up to 144Mb 18-bit wide QDRII+ SRAM running at a maximum clock rate of 550MHz. They offer a potential 2.2 GBytes/s raw bandwidth each.

This makes the architecture ideal for implementing advanced algorithms that require buffering or fast look-up tables.

An 8-lane PCI Express Gen 3 host interface with built-in DMA channels optimized for fast data transfers provides unmatched bandwidth and speed while moving data between the card and the host memory. PCI Express Gen 3 doubles the effective bandwidth and adds protocol enhancements to increase end-system performance. The V5031 card has the ability to reconfigure the FPGA device without bringing down the host interface, a key requirement for applications where frequent downtime is not an option.

The V5031 card has a high-speed, low-latency transceiver interface that allows direct communication between two cards in the system without host intervention. This is particularly useful for applications requiring extensive processing. It also allows for a soft handover, an essential feature for high availability system design.

The V5031 card features an RS-232 interface and a software utility for debugging FPGA applications. The card's pulse per second (PPS) interface can be used for time synchronization and stamping of data. It also supports the IEEE 1588 Precision Time Protocol (PTP). The V5031 card comes with on-board temperature sensors with shut-down and automatic restart capability. The Stratix V loads from an on-board FLASH with support for two boot images

# V5031

## Quad-Port PCI Express FPGA Card

### Functional Description Continued

The V5031 ships with the expressXG Development Framework, a fully integrated package designed to deliver optimum functionality and accelerate application development on the V5031 network card. New Wave DV's flexible FPGA development framework toolset provides the infrastructure necessary to ensure rapid deployment of applications and allows seamless portability to the latest generation of network interface cards. The framework abstracts the details of Ethernet protocols and interfaces, memory controllers and host fabric interfaces, thereby reducing the development effort and schedule for designers to implement custom algorithms.

New Wave DV ensures extreme reliability that gives customers confidence to deploy their products in critical applications. Like other products in the same family, the V5031 card is compatible with several high-performance servers from leading OEMs, such as HP ProLiant DL380. This single slot solution allows customers to maximize the number of cards per server, resulting in a smaller server footprint.

### Complete Product Support Program

New Wave DV prides itself on its excellent customer support, a fact that is echoed by our customers. New Wave DV provides industry standard warranty on its products, but it is the human factor that makes our support so valuable to our customers. Our team takes the time and effort to ensure that the customer experience with our products is a positive one.

### Our Commitment

New Wave DV is committed to providing the latest innovations in technology, architectures, and techniques to keep our customers one step ahead of the rest. Our products, complete with expressXG Development Framework, are intended to offer our customers an entirely unique out-of-the-box experience.

### Technical Specifications

#### NETWORK INTERFACE

Quad 1/10 Gigabit Ethernet SFP/SFP+ optical ports, supporting MMF 850nm (10GBASE-SR) or SMF 1310nm (10GBASE-LR)

#### FPGA DEVICE

Altera Stratix V (scalable from A3 to AB)

#### MEMORY

2 banks of 1GB to 8GB 72-bit up to 1066MHz DDR3 SDRAM  
4 banks of 36Mbit to 144Mbit 18-bit 550MHz QDRII+ SRAM

#### HOST INTERFACE

x8 PCI Express Gen 3

#### EXTERNAL INTERFACE

Mini SAS transceiver interface for intercard communication  
PPS Interface for time synchronization with microsecond resolution  
RS-232 serial interface for debug

#### SYSTEM REQUIREMENTS

X86 64-bit processor 2GHz or better, 1GB RAM, 1GB disk spaces  
Free PCI Express x8 or x16 slot

#### COMPLIANCE

PCI Express Card Electromechanical Specification, Rev 2.0 IEEE  
802.3ae 2002 10GBASE  
FCC 47 CFR Part 15, Subpart B, Class A (USA)  
IEC 60950-1 (International)  
RoHS Directive 2002/95EC

#### DIMENSIONS

111.15 mm x 167.65 mm (standard height, half-length)

#### TEMPERATURE

Operating: 0 to 45°C  
Storage: -40° C to 85° C

#### ORDERING INFORMATION

300-05031-02 — V5031 Stratix V GXA7 800MHz 2x1GB 4x36Mb 50MHz  
300-05031-03 — 5031 Stratix V GXA7 800MHz 2x4GB 4x144Mb 550MHz  
300-05031-05 — V5031 Stratix V GXA3 800MHz 2x1GB 4x36Mb 550MHz

Other product configurations are available. Please contact us for more information.

#### FOR MORE INFORMATION:

www.newwavedv.com  
info@newwavedv.com  
Phone +1 952-224-9201

New Wave DV  
4950 W 78th St. Minneapolis,  
MN 55416 USA

