

V1131

Quad Channel 10 Gigabit Ethernet XMC Card

Benefits

- Highest density 10 Gigabit Ethernet XMC for next generation radar and signal intelligence systems
- A COTS solution optimized for SWaP (size, weight and power)
- A programmable FPGA with a powerful development framework
- Real time data streaming directly from sensors

Features

- Four 10 Gigabit Ethernet SFP+ optical ports
- Altera Stratix V FPGA device
- Robust FPGA development framework
- Available with advanced APIs that support multi-core and multi-processor architectures
- Optimized VxWork and Linux drivers and libraries
- Supports PCIe and XAUI host interfaces
- PPS interface for time synchronization with μ Sec resolution
- Thermal sensors for monitoring card temperature
- UDP offload engine for real time communication
- Streaming front-end FPGA core for quick sensor integration
- Available in air and conduction-cooled XMC form factors

Overview

Reducing system size, weight and power (SWaP) is critical for operational life and budgetary constraints of military radar and remote sensing systems. The requirement for increasingly higher port density and processing power to support larger arrays, while still staying within SWaP and budget requirements, is a significant challenge to engineering architects. New Wave DV satisfies these requirements with the V1131 Quad Channel 10 Gigabit Ethernet XMC Card — doubling port density with plenty of FPGA resources to process data and support for both PCIe and XAUI host connectivity.

Doubling Density and Increased Flexibility

The V1131 is the industry's most advanced XMC solution designed to provide a real time high-bandwidth network interface and processing module for next generation radar and signal intelligence systems. It comes with a range of Stratix V FPGAs (A3 to A7), different memory configurations to meet application requirements, and support for different carrier boards using PCIe and XAUI. Design flexibility to meet application requirements results in optimized SWaP, shorter development cycle, and enhanced performance. The V1131 doubles existing port density with four 10 Gigabit Ethernet SFP+ optical interfaces.



V1131

Quad Channel 10 Gigabit Ethernet XMC Card

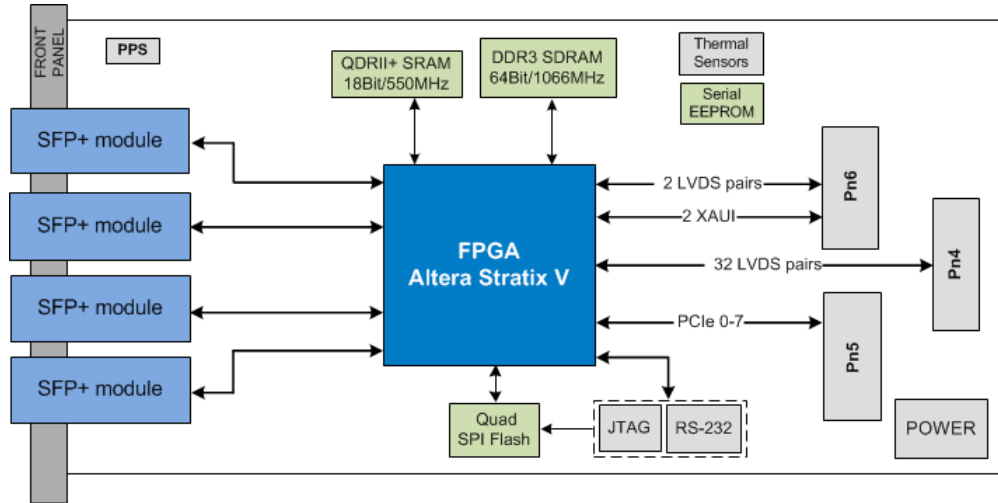

> V1131 Quad Channel 10GE XMC Block Diagram

Simplified Programmability Framework

The V1131 ships with the expressXG Development Framework, a fully integrated and flexible toolset that provides the infrastructure necessary to ensure rapid deployment of applications. The framework abstracts the details of Ethernet protocols and interfaces, memory controllers and host fabric interfaces, thereby reducing the development effort and schedule for designers to implement custom solutions. High performance software libraries and drivers ensure that the card is running “out of the box”.

Optional Ethernet Offload Over PCIe Module

The V1131 has built-in support for UDP, ARP and ICMP communication protocols. When used as a gateway, the V1131 supports PCI Express over the Pn5 connector for processor communication and comes with high level APIs for control and data transfer resulting in a simplified programming model.

Multi-processor Multi-core Support

The V1131 is uniquely suited to system architectures involving multiple processing cards on a common switched data plane. Specifically, the V1131 supports shared access from multiple host processors, enabling it to function as a cost effective, high-performance 10 Gigabit Ethernet gateway. This feature enables a single high-speed pipe to carry multiple virtual channels in systems that need to spread or load balance sensor data across processor farms.

Simplified Programmability Framework

The V1131 is unique in its ability to directly transfer data between 10 Gigabit Ethernet networks and FPGA devices. This minimizes the size and power footprint of systems by obviating the need to introduce additional processors solely to run Ethernet communications. A Streaming Front End (SFE), which is a small core that resides on the FPGA device, provides an independent interface to each 10 Gigabit Ethernet channel on the V1131.

New Wave DV ensures extreme reliability that gives customers confidence to deploy their products in critical applications.

V1131

Quad Channel 10 Gigabit Ethernet XMC Card

Complete Product Support Program

New Wave DV prides itself on its excellent customer support, a fact that is echoed by our customers. New Wave DV provides industry standard warranty on its products, but it is the human factor that makes our support so valuable to our customers. Our team takes the time and effort to ensure that the customer experience with our products is a positive one.

Our Commitment

New Wave DV is committed to providing the latest innovations in technology, architectures, and techniques to keep our customers one step ahead of the rest. Our products, complete with expressXG Development Framework, are intended to offer our customers an entirely unique out-of-the-box experience.

Ordering Information

300-01131-01 — V1131 Quad 10GE XMC Line Card Stratix V GX4, 2GB SDRAM, 36Mbit SRAM (air cooled)

300-01131-02 — V1131 Quad 10GE XMC Line Card Stratix V GX4, 2GB SDRAM, 36Mbit SRAM (conduction cooled)

Other product configurations are available. Please contact us for more information.

Technical Specifications

NETWORK INTERFACE

Four 10GBASE-SR or 10GBASE-LR SFP+ optical ports

ETHERNET PROTOCOLS

UDP, ARP, ICMP, Multicast, Broadcast

FPGA DEVICE

Altera Stratix V 5SGXMA3H2F35C2N to 5SGXMA7H2F35C2N

MEMORY

One bank of 1GB to 2GB 64-bit up to 800MHz DDR3 SDRAM
One bank of 36Mbit to 144Mbit 18-bit 550MHz QDRII+ SRAM

FLASH

One 32MB memory for storing a default configuration image

HOST INTERFACE

PCI Express x8 or two XAUI over Pn5
Two XAUI over Pn6

EXTERNAL INTERFACE

32 differential pairs (user configurable)
PPS Interface for time synchronization with μ second resolution
RS-232 serial interface for debug

THERMAL SENSORS

2 digital temperature sensors

COMPLIANCE

VITA 42.3
VITA 42.6
IEEE 802.3ae 2002 LAN

DIMENSIONS

74 mm (width) x 149 mm (length)

POWER REQUIREMENTS

Maximum 35W

TEMPERATURE

Operating: 0° C to 45° C at 600 LFM (air cooled)
Operating: -40° C to 70° C (conduction cooled)
Storage: -40° C to 85° C

FOR MORE INFORMATION

www.newwavedv.com
info@newwavedv.com
Phone +1 952-224-9201

New Wave DV
4301 Highway 7
Suite 190
St. Louis Park, MN 55416, USA

